

CENTER GLAZED INSTALLATION INSTRUCTION

SERIES 250 CENTER GLAZED (2" x 4 1/2")

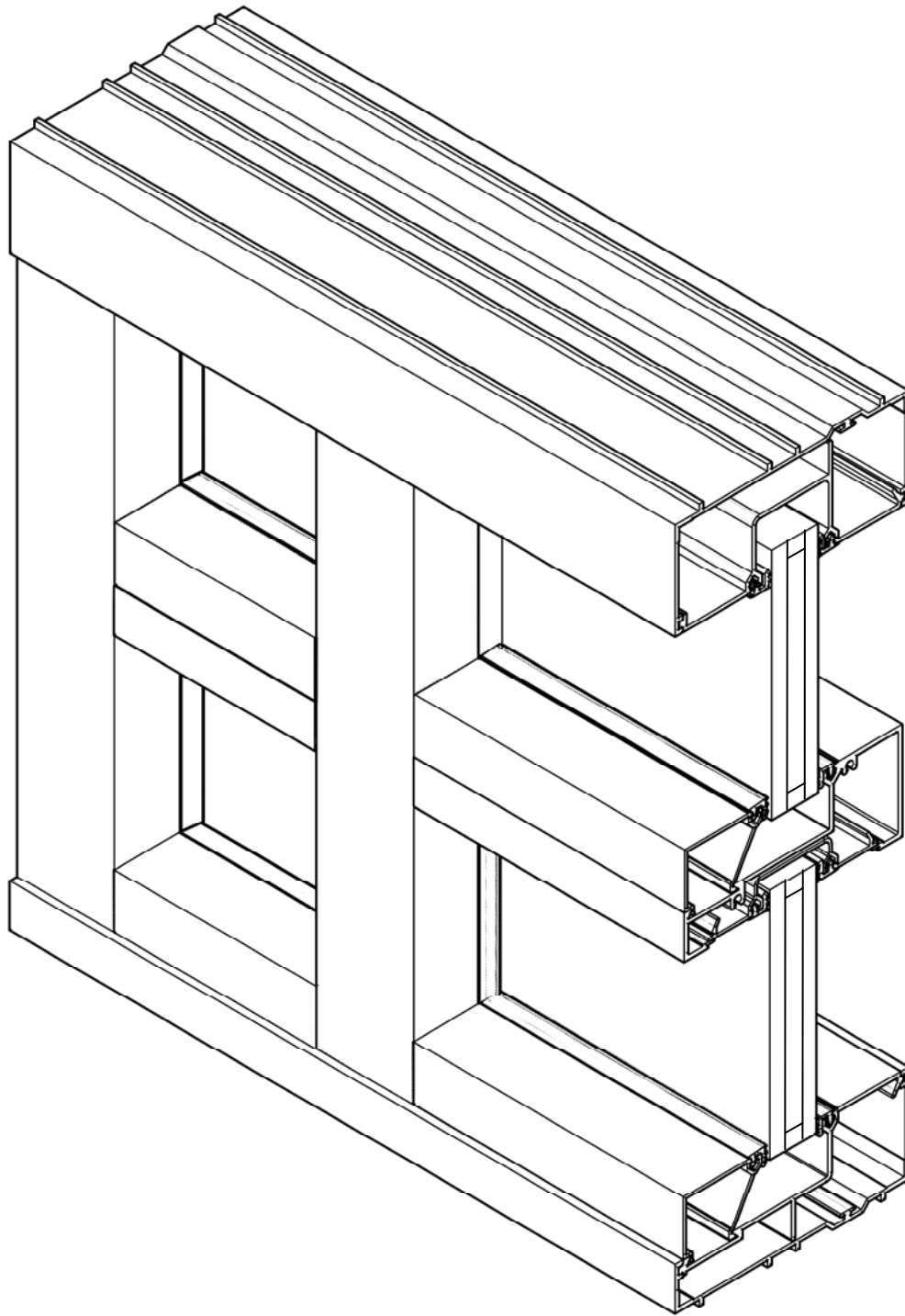

SERIES 250 CENTER GLAZE SYSTEM

TABLE OF CONTENTS

GENERAL NOTES.....	Sheet 2 and 3
FRAME FABRICATION	Sheet 4 -5
FRAME INSTALLATION	Sheet 5 -8

INSTALLATION INSTRUCTIONS

GENERAL NOTES

HANDLING, STORAGE AND PROTECTION OF ALUMINUM

The following precautions are recommended to protect the material against damage. Following these precautions will help ensure early acceptance of your products and workmanship.

A. HANDLE CAREFULLY

All aluminum materials at job site must be stored in a safe place well removed from possible damage by other trades. Cardboard wrapped or paper interleaved materials must be kept dry.

B. CHECK ARRIVING MATERIALS.

Check for quantity and keep records of where various materials are stored.

C. KEEP MATERIAL AWAY FROM WATER, MUD AND SPRAY.

Prevent cement plaster or other materials from damaging the finish.

D. PROTECT THE MATERIALS AFTER ERECTION.

Protect erected frame with polyethylene or canvas splatter screen. Cement, plaster, terrazzo, other alkaline solutions and acid based materials used to clean masonry are harmful to the finish. ***If any of these materials come in contact with the aluminum, IMMEDIATELY remove with water and mild soap.***

*The rapidly changing technology within the architectural aluminum products industry demands that **PRL Aluminum** reserve the right to revise, discontinue or change any product line, specification or electronic media without prior written notice.*

GENERAL INSTALLATION NOTES

RECOMMENDED GUIDELINES FOR ALL INSTALLATIONS:

1. **REVIEW CONTRACT DOCUMENTS.** Check shop drawings, installation instructions, architectural drawings and shipping lists to become thoroughly familiar with the project. The shop drawings take precedence and include specific details for the project. Note and field verified notes on the shop drawings prior to installing. The installation instructions are of general nature and cover most conditions.
2. **INSTALLATION.** All materials are to be installed plumb, level and true.
3. **BENCH MARKS.** All work should start from benchmarks and/or column lines as established by the architectural drawings and the general contractor with guaranteed accuracy. Working from these datum points and lines determine:
 - a) The plane of the wall in reference to offset lines provided on each floor.
 - b) The finish floor lines in reference to benchmarks on the outer building columns.
 - c) Mullion spacing from both ends of masonry opening to prevent dimensional build-up of daylight opening.
4. **FIELD WELDING.** All field welding must be adequately shielded to avoid any splatter on glass or aluminum. Results will be unsightly and/or structurally unsound. Advise general contractor and other trades accordingly. All field welds of steel anchors must receive touch-up paint (zinc chromate) to avoid rust.
5. **SURROUNDING CONDITIONS.** Make certain that construction, which will receive your materials, is in accordance with the contract documents. If not, notify the general contractor in writing and resolve differences before proceeding with work.
6. **ISOLATION OF ALUMINUM.** Aluminum to be placed in direct contact with uncured masonry or incompatible materials should be isolated with a heavy coat of zinc chromate or bituminous paint.
7. **SEALANTS.** Sealants must be compatible with all materials with which they have contact, including other sealant surfaces. Consult with sealant manufacturer for recommendations relative to joint size, shelf life, compatibility, cleaning/priming, tooling, adhesion, etc. It is the responsibility of the Glazing Contractor to submit a statement from the sealant manufacturer indicating that glass and glazing material have been tested for compatibility and adhesion with glazing sealants, and interpreting test results relative to material performance, including recommendations for primers and substrate preparation required to obtain adhesion. The chemical compatibility of all glazing materials and framing sealants with each other and with like materials used in glass fabrication must be established. This is required on every project.
8. **FASTENING.** Within the body of these instructions "fastening" means any method of securing one part to another or to adjacent materials. Only those fasteners used within the system are specified in these instructions. Due to the varying perimeter conditions and performance requirements perimeter and anchor fasteners are not specified in these instructions. For perimeter and anchor fasteners refer to the shop drawings or consult the fastener supplier.
9. **BUILDING CODES.** Due to the diversity in state/provincial local and federal laws and codes that govern the design and application of architectural products it is the responsibility of the individual architect owner and installer to assure that products selected for use on projects comply with all the applicable building codes and laws. **PRL ALUMINUM, INC.** exercises no control over the use or application of its products, glazing materials and operating hardware and assumes no responsibility thereof.
10. **EXPANSION JOINTS.** Expansion joints and perimeter seals shown in these instructions and in the shop drawings are shown at normal size. Actual dimensions may vary due to perimeter conditions and/or difference in metal temperature between the time of fabrication and the time on installation. Gap between expansion members should be based on temperature at time of installation.
11. **WATER HOSE TEST.** As soon as a representative amount of the wall has been glazed (500 square feet) a water hose test should be conducted in accordance with AAMA 501.2 specifications to check the installation. On all jobs the hose test should be repeated every 500 square feet during the glazing operation.
12. **COORDINATION WITH OTHER TRADES.** Coordinate with the general contractor any sequence with other trades, which offset curtain wall installation (i.e. fire proofing, back-up walls, partitions, ceilings, mechanical ducts, converters etc.)
13. **CARE AND MAINTENANCE.** Final cleaning of exposed aluminum surfaces should be done in accordance with AAMA 609.1 anodized aluminum and 610.1 for painted aluminum.

CENTER GLAZE INSTALLATION INSTRUCTIONS

Details in these instructions are for Series "250" members.

Measure ROUGH OPENING minus perimeter seal joint to determine FRAME DIMENSION.
Allow 1/4" minimum clearance for shimming and sealant around perimeter.

FRAME FABRICATION

1. Cut member to size :

Head and Sill channels:	(Parts 251HC and 251SC)	FRAME WIDTH
Wall Jamb and Vertical:	(Parts 251WJ AND 251VM)	FRAME HEIGHT minus 1/2"
Head and Sill fillers :	(Parts 251HCF AND 251HM)	D.L.O. -1/32"
Horizontal members:	(Parts 251HM)	D.L.O. -1/32 "
Intermediate Horizontal fillers:	(Parts 251HMF)	D.L.O. -1/32"
Horizontal glazing stop:	(Parts 251GS-H)	D.L.O. -1/32"
Sill channel glazing stop:	(Parts251GS)	D.L.O. -1/32"

The schematic shapes below show each horizontal members.

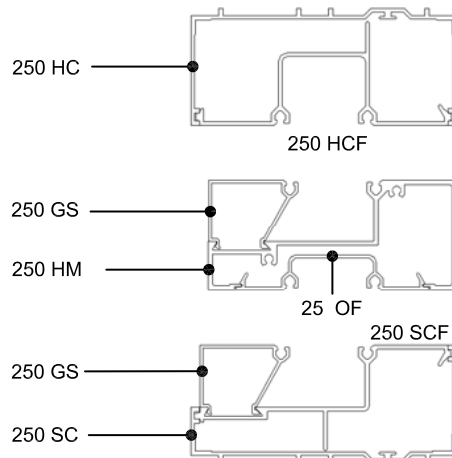

"Sketch 101"

"EXTERIOR GLAZING"

2. Drill 5/16" diameter weep holes in sill channel, two per lite @ 3" from vertical mullion. Weep slots may be drilled in face or bottom of sill channel. See "Sketch 104".
3. Mark horizontal locations on mullion and with drill jigs, drill holes for assembly screws. The use of drill jigs is recommended.
4. Prepare end of horizontals for # 10 x 1/2" F.H.S.M. anchor screws. See "Sketch 106".

5. Apply end dams to head and sill channel at ends and secure with screws.
Seal around and up joint to make water tight. See Sketch 102 below.

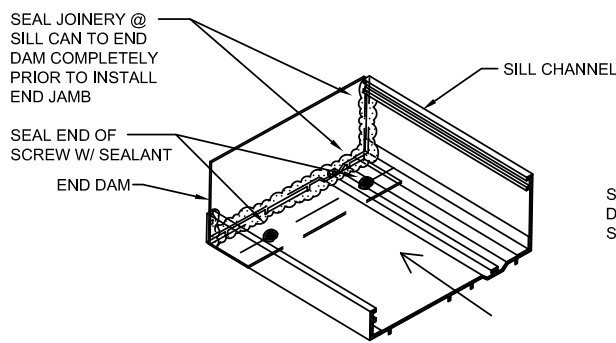

① SILL CAN END DAM

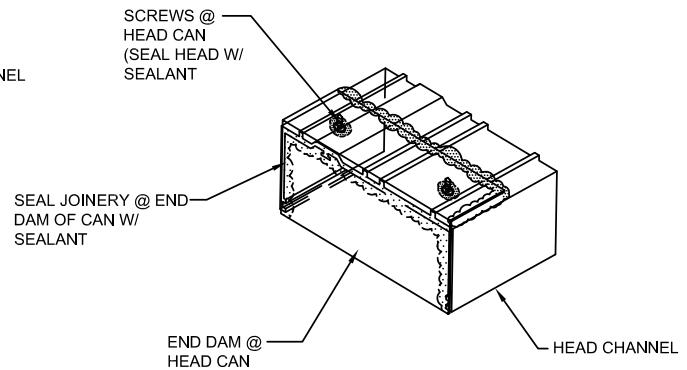

② HEAD CAN END DAM

NOTE:
Clean all surfaces prior to applying sealants. See sealant manufacturer requirements.

"SKETCH 102 "

FRAME INSTALLATION

1. Set head and sill channels in place plumb and square; shim as required to level and anchor to structure. Locate fasteners 6" from end of channel and 24" o.c. or as require per engineer. Holes for fasteners should be slotted horizontally to allow for thermal movement and seal over fastener head with sealant. Hard anchor head and sill channel to structure at mid-point of cut lenght. Shim sill and head channel at fastener locations. See "SKETCH 104". Make sure sill channel remains clean of debris during installation to prevent blockage of weep holes.

2. Install jamb member into head and sill channels. Shim and plumb as require. See "Sketch 103" below.

Shim as required.
Note: Do not shim behind end dam.

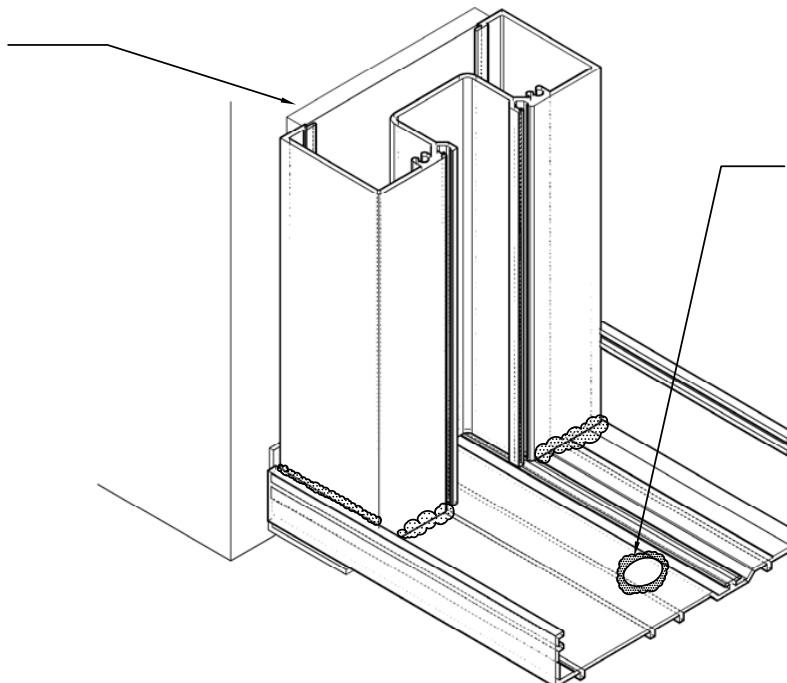

"SKETCH 103 "

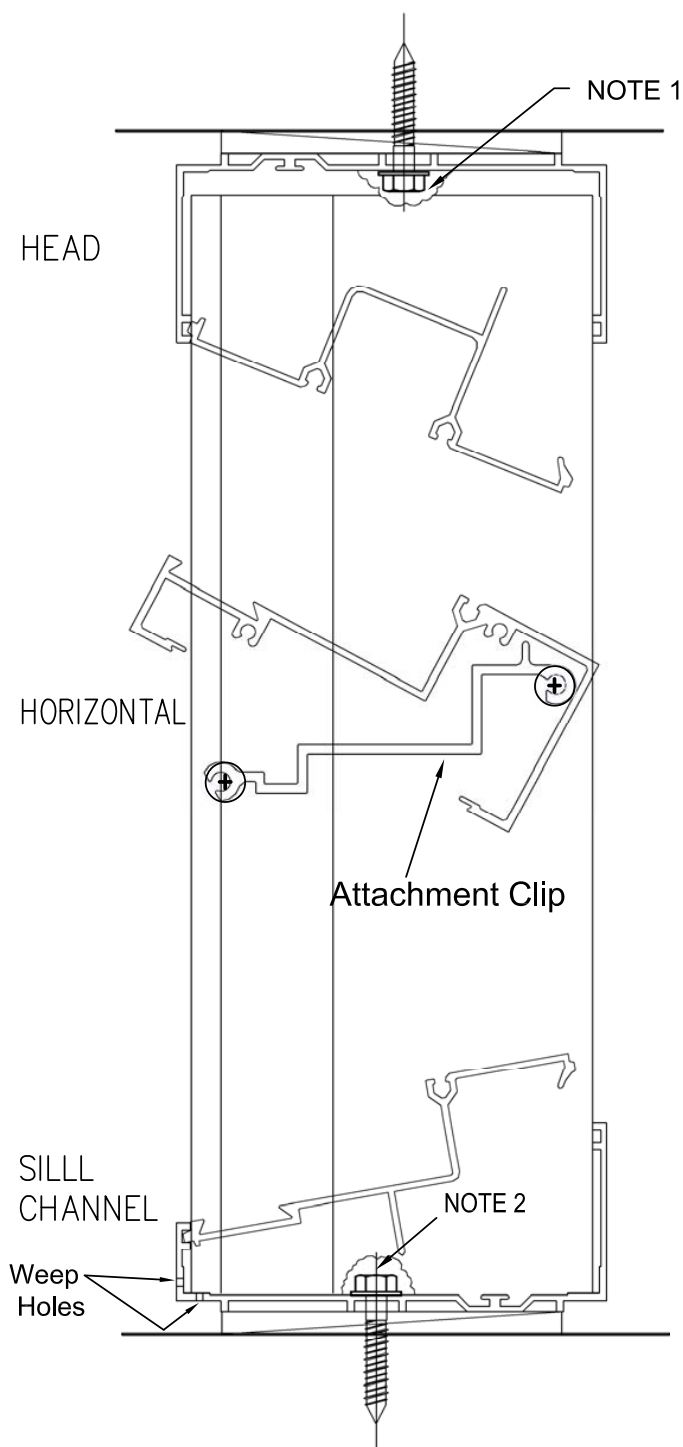

"SKETCH 104"

NOTE 1: Seal head of fastener at head if no interior perimeter seal.

NOTE 2: Critical seal, carefully seal over head of fasteners at sill only.

3. Snap-in head and sill fillers for the first glass bay. See "Sketch 104"
4. Install next vertical tight against head and sill fillers. NOTE: Verticals for 1" glazing are not symmetrical. **Never allow two shallow pockets to face each other. Seal joint where verticals meet head and sill. Verticals must be secured to head/sill channels when end reactions exceed 500lbs.**
5. Snap-in head and sill filters for the second glass bay and repeat steps 4 and 5 until all verticals are installed and all head and sill inserts are snapped-in place. At the last glass bay install wall jamb in place before snapping head and sill fillers. **Note: A check should be made every four bays to monitor accumulation of horizontal members cutting tolerances.**
6. Butter anchor clip contact areas and joints prior to horizontal installation. See "Sketch 105" below.

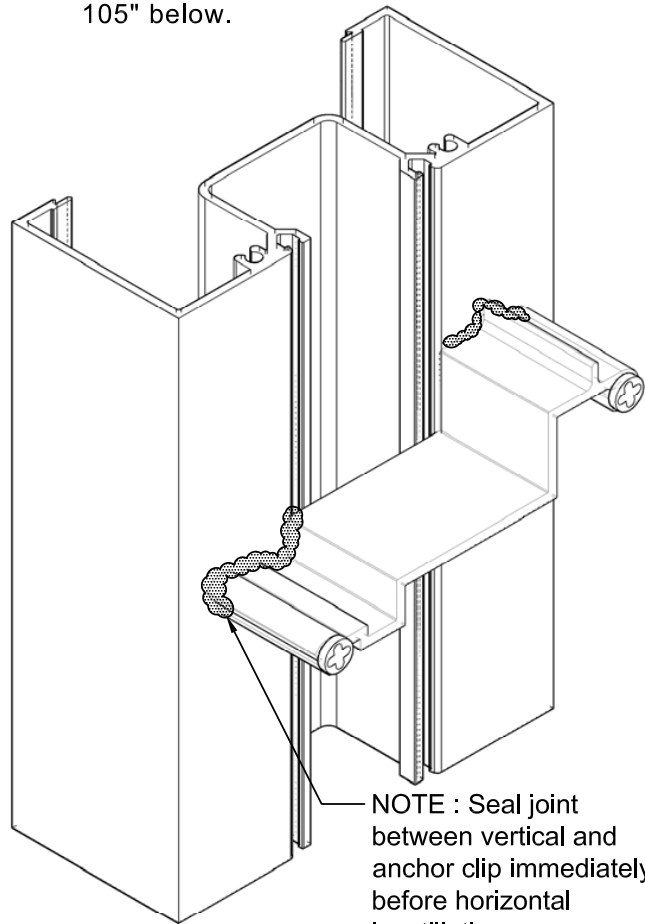

"SKETCH 105"

7. Set horizontals over anchor clips and secure with screws provided. See "Sketch 106".

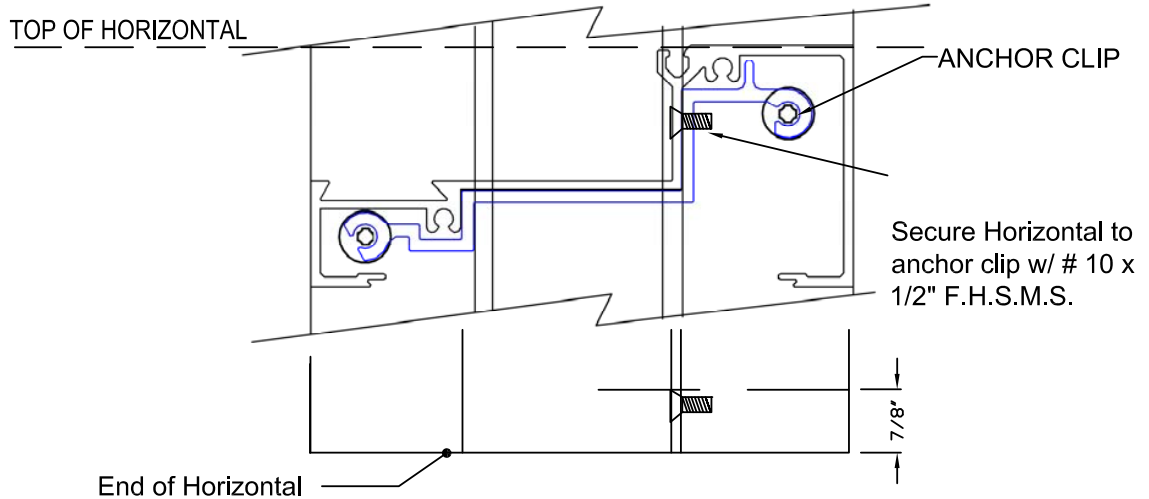

"SKETCH 106"

EXTERIOR GLAZING

WHEN USING TUBULAR HORIZONTALS

8. Butter anchor clip contact areas and joints with sealant. See "Sketch 107".
9. Slide hollow horizontal over anchor clip. See "Sketch 107".
10. Install next vertical tight against head and sill fillers. NOTE: Verticals are not symmetrical.
Never allow two shallow pockets to face each other.
Verticals must be secured at top and bottom when end reactions exceed 500lbs.

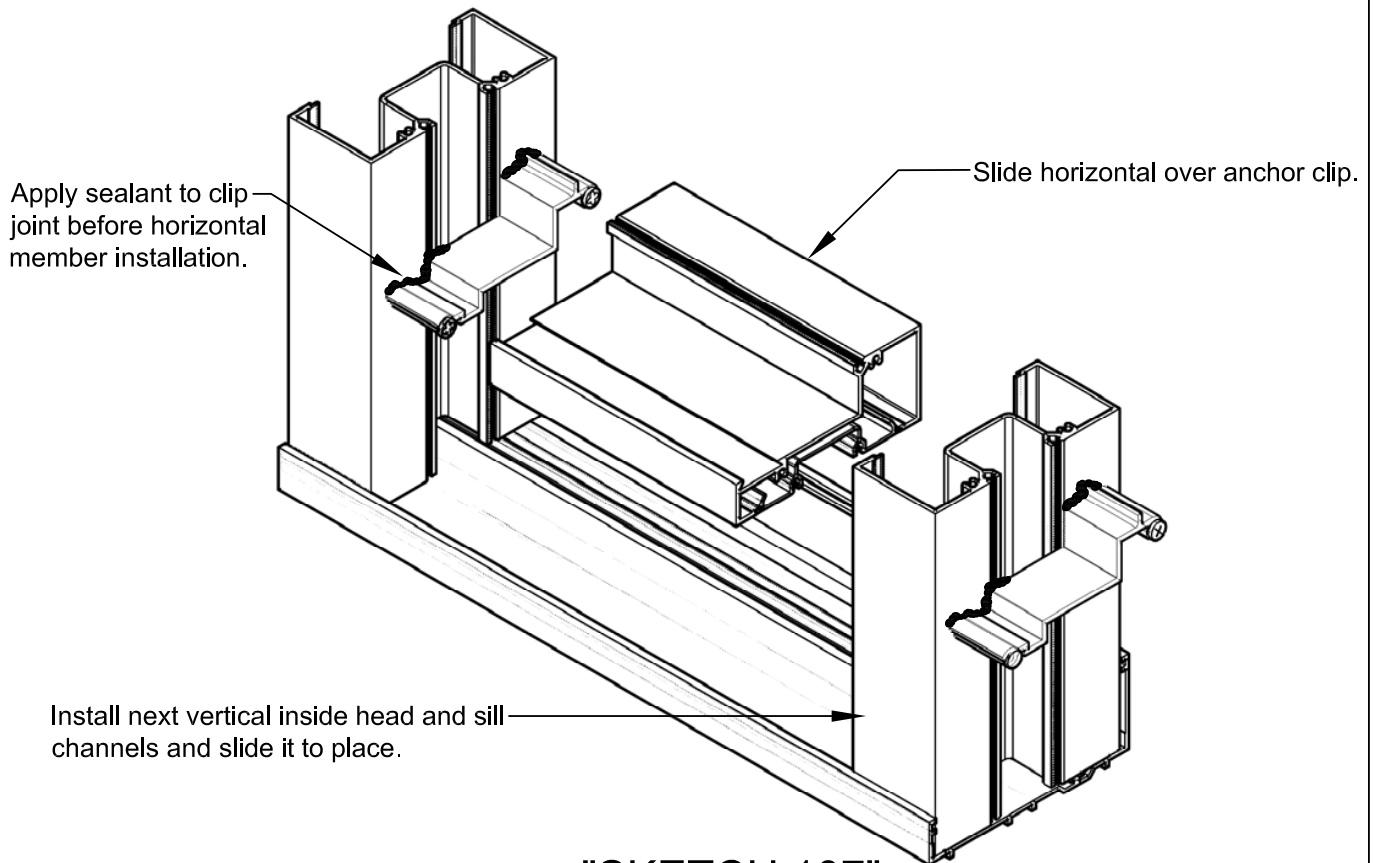

"SKETCH 107"

11. Apply silicone to vertical glazing pocket and gasket reglet at vertical/horizontal intersection. Silicone must be applied to two sides of pocket only. Clearance at outside will allow infiltrated water to run down to subsill. See "Sketch 108".
12. Insert water deflectors into glazing pocket and into position. See "Sketch 109".

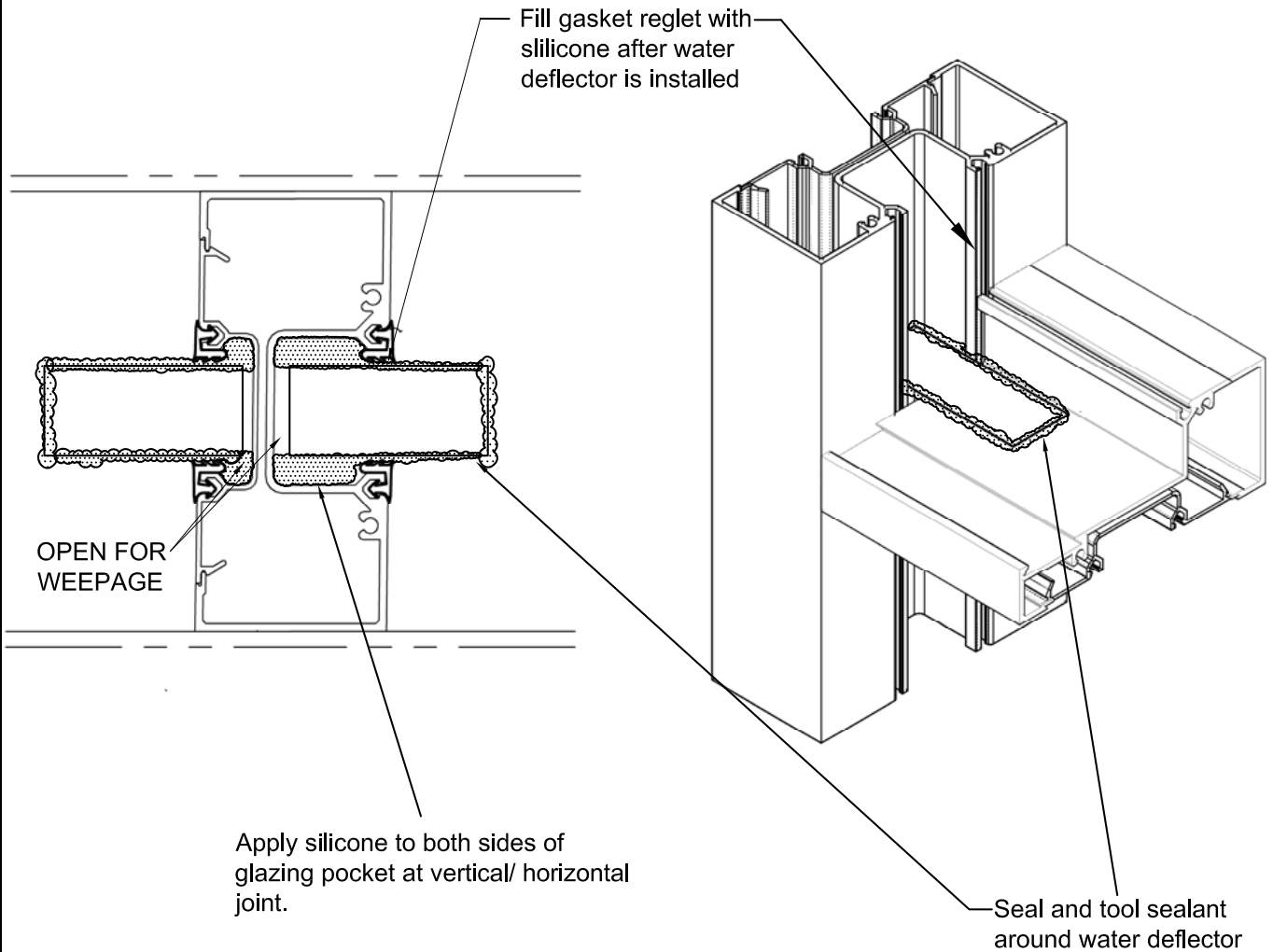

"SKETCH 108"

"SKETCH 109"